



TECHNOLOGY IN MOTION

The work described in these installation instructions may only be carried out by specialist companies.



Read thoroughly before use or installation!
Keep for future reference!

MACO PROTECT

DOOR LOCKS

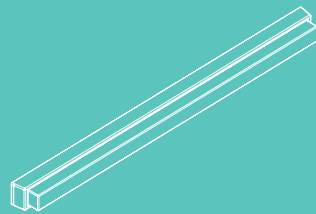
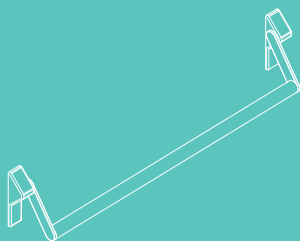

INSTALLATION INSTRUCTIONS

for emergency exit doors to EN 179
and panic doors according to EN 1125
1-sash
with E changeover function
with door lock A-TS

Legends and abbreviations





	DM	Backset dimension
	E	Distance
	GM	Handle size
		Cut-to-length range
		Profile front edge
	A-TS	3-latch automatic lock
	FFH	Sash rebate height
	HO	Hook upwards
	K+	Box size top
	K-	Box size bottom
	MF	Multifunctional latch



Table of contents

1. Notes for using these installation instructions	5
2. Safety and warning notices	8
3. Storage and transport of the fitting / door or window element	9
3.1 Notes on storing and transporting the fitting	9
3.2 Notes on transporting and handling the door or window elements.....	9
3.3 Use of transport securing devices	10
4. Technical data	11
5. Certificates and proof of performance	12
5.1 Information according to EN 179 or EN 1125.....	12
5.2 Classification key according to EN 179:2008	13
5.3 Classification key according to EN 1125:2008	14
5.4 Certificate.....	15
5.5 Declarations of performance	15
6. Intended use.....	16
7. Reasonably foreseeable misuse	17
8. Notes for the processing	20
9. Notes on differentiating between emergency exit and panic doors.....	22
10. E changeover function.....	23
11. Installation and fastening instructions for the fabricator, which are required directly in the EN 179 and EN 1125 standards.....	24
12. Additional instructions for fabricators for the use of emergency exit and panic door locks (EN 179 and EN 1125) in fire and smoke protection doors	26
13. Authorised system components and adaptations of locks for use in emergency exit and panic door locks	27
14. Latch changeover and replacement of detached latch.....	29
15. Installation instructions	30
15.1 Set up lock for mechanical day release function (Fabricator, only EN 179)	30
15.2 Installation of day release element on the lock (fabricator, EN 179 only)	31
15.3 Installation of MACO day release opener with permanent opening on the striker plate (fabricator, EN 179 only)	32
15.4 Day release feature operating instructions (end customer, EN 179 only)	33

16. General positioning of striker plates and single piece door strikers	34
17. Timber profile door constructions	35
17.1 4 mm rebate clearance	35
17.2 12 mm rebate clearance.....	35
18. Timber profile drilling and milling images	36
18.1 Lock box and multifunctional latch with hook locking.....	36
18.2 Latch and bolt striker plate 13 mm offset.....	37
18.3 Multifunctional hook striker plate 13 mm offset	38
19. Positioning of timber profile striker plates	39
19.1 4 mm rebate clearance, 13 mm offset.....	39
19.2 12 mm rebate clearance, 13 mm offset	39
20. PVC profile drilling and milling images.....	40
20.1 Lock box and multifunctional latch with hook locking.....	40
20.2 Latch and bolt striker plate.....	41
20.3 Multifunctional hook striker plate	41
21. Positioning PVC profile striker plates.....	42
22. Aluminium profile drilling and milling images.....	43
22.1 Lock box and multifunctional latch with hook locking.....	43
22.2 Latch and bolt striker plate 3 mm.....	44
22.3 Multifunctional hook striker plate 3 mm	44
22.4 Latch and bolt striker plate 6 mm	45
22.5 Multifunctional hook striker plate 6 mm.....	45
23. Positioning aluminium profile striker plates.....	46
24. Composite drilling and milling images	47
24.1 Lock box and multifunctional latch with hook locking.....	47
24.2 Latch and bolt striker plate for sash thickness 48 mm	48
24.3 Multifunctional hook striker plate for sash thickness 48 mm.....	48
24.4 Latch and bolt striker plate for sash thickness 44 mm.....	49
24.5 Multifunctional hook striker plate for sash thickness 44 mm.....	49
25. Positioning composite striker plates.....	50
26. Disposal of the fitting	51



1. Notes for using these installation instructions

Target group

- › These installation instructions are intended exclusively for specialised companies and trained specialist personnel (e.g. carpenters, metalworkers for construction technology, window and glass façade installers).
- › The work described in these installation instructions may only be carried out by specialist personnel! This also applies in particular to electrical work, which may only be carried out by qualified electricians.

Before starting installation ...

- › Read these installation instructions carefully before starting installation. Install all components professionally and only as described in these installation instructions and observe all safety and hazard information.
- › The use of system accessories not expressly approved by MACO, modifications or repair work not expressly authorised by MACO and improper servicing can lead to malfunctions and must be avoided. Repairs are generally excluded. In the event of failure, the entire fitting part must be replaced.
- › Failure to comply with the installation, safety and hazard information described in these installation instructions does not guarantee the proper functioning of the fitting; this leads to the immediate loss of warranty, guarantee, compensation, product liability claims and other liability claims against MACO. MACO accepts no liability for any damage to persons or material resulting from improper installation or installation contrary to the instructions given in these installation instructions.
- › Failure to comply with the installation instructions will also result in the immediate loss of any outstanding claims arising from any existing warranty agreement.
- › Coordinate the required fastening material with the structure and the corresponding load and supplement it if necessary. Any fastening material supplied only fulfils part of the requirements.
- › To fasten the parts, use sufficiently long screws, which should extend into the steel reinforcement if possible in the case of PVC profiles.
- › Test doors and safety elements. The intactness and ease of movement of the doors must be ensured.
- › All work (installation, adjustment, etc.) must be carried out in a de-energised state.
- › Before installing the drive, check that the applicable temperature range is suitable for the environment.

Usage instructions

- › These installation instructions are revised on an ongoing basis and the latest version is available for download at <https://www.maco.eu/assets/760368>. The QR code, which takes you directly to the latest version, and the creation date can be found at the end of these installation instructions.
- › All illustrations are only symbolic and serve only for better visualisation.
- › Unless otherwise stated, dimensions are given in **millimetres**.
- › Further information on our currently available products can be found on our website www.maco.eu.
- › If in doubt, please consult your MACO contact person!
- › Please send any suggestions or ideas for improving our installation instructions by email to feedback@maco.eu

Protective note on the restriction of the use of documents in accordance with ISO 16016: © Mayer & Co Be-schläge GmbH.

Applicable documents

The following documents must be observed in addition to these instructions and/or provide additional information:

- › Online catalogue eCat at <https://ecat.maco.eu/>
- › Operating and maintenance instructions for end users - order number [760364](#)
- › Installation instructions A-TS Comfort motor, access solutions and interfaces - order number [760322](#)
- › Maintenance log for emergency exit and panic doors - order number [760372](#)
- › Installation instructions electrical and mechanical door opener - order number [760320](#)

You can find the current version of our documents on our website at <https://www.maco.eu/Downloads>.

The specialist company's obligation to provide information and training

Please note that it is your duty to inform and train the end user!

As the distributor, you are obliged to deliver the window or door elements exclusively including the applicable operating and maintenance instructions and, if applicable, a sticker for deviating operating methods. We make these available to our customers in the download area of our website (<https://www.maco.eu/Downloads>).

End users must be trained accordingly.

Retention of documents



Keep these installation instructions for future reference.

2. Safety and warning notices

These installation instructions contain safety instructions before a sequence of actions that could result in personal injury or material damage. The hazard prevention measures described must be strictly adhered to.

For the safety of personnel, there are safety instructions in the following 3 stages:



DANGER

Imminent danger!

Failure to comply with such instructions will result in death or serious injury!



WARNING

Possible imminent danger!

Failure to comply with such instructions can result in death or serious injury!



BEWARE

Possible imminent danger!

Failure to comply with such instructions may result in minor or slight injuries!

In addition, installation steps that require special attention are labelled with the following note:



CAUTION

Note to avoid material damage or errors when installing the fitting on the element.

3. Storage and transport of the fitting / door or window element

Check the following immediately upon delivery:

- › damage to packaging or containers
- › damage to the material
- › other obvious irregularities

3.1 Notes on storing and transporting the fitting

Improper storage and transport of the fitting can impair the surface quality. This can result in the safety and function of the fitting no longer being guaranteed. To prevent this, the following points must be observed:

- › It must be ensured that the room air is permanently dry (max. 60% relative humidity).
- › Avoid large temperature fluctuations that lead to the formation of condensation. Condensate on the fitting leads to the galvanised surfaces being attacked (rust formation).
- › Aggressive vapours from cleaning agents or installation aids such as silicone and the like must be avoided at all costs - even for short periods. Vapours from such substances can very quickly lead to corrosion of fittings.
- › Salty air or air polluted by trade and industry also leads to corrosion on galvanised surfaces and is also unsuitable for storage facilities.

3.2 Notes on transporting and handling the door or window elements



WARNING

Possible danger to life and limb due to improper handling and transport! Follow the instructions.

Improper handling and improper transport of the doors/windows or French door elements can lead to dangerous situations and cause serious accidents or even death. To prevent this, the following notes must be observed:

- › During loading and unloading processes, force application points must be selected that only generate reactive forces in accordance with the design of the fitting for the intended installation position.
- › During handling and transport, ensure that the fitting is in the locked position to prevent the sash from swinging open in an uncontrolled manner. Suitable securing devices must be used.
- › Only transport securing devices that are matched to the respective rebate clearance may be used.
- › Transport must be carried out in the intended installation position. If transport in the intended installation position is not possible, the sash must be unhinged and transported separately from the associated frame.

3.3 Use of transport securing devices

Simple transport securing devices, wedges or blocks ensure safe transport of the entire door element. Do not remove until after installation.

Ⓐ Transport securing device position

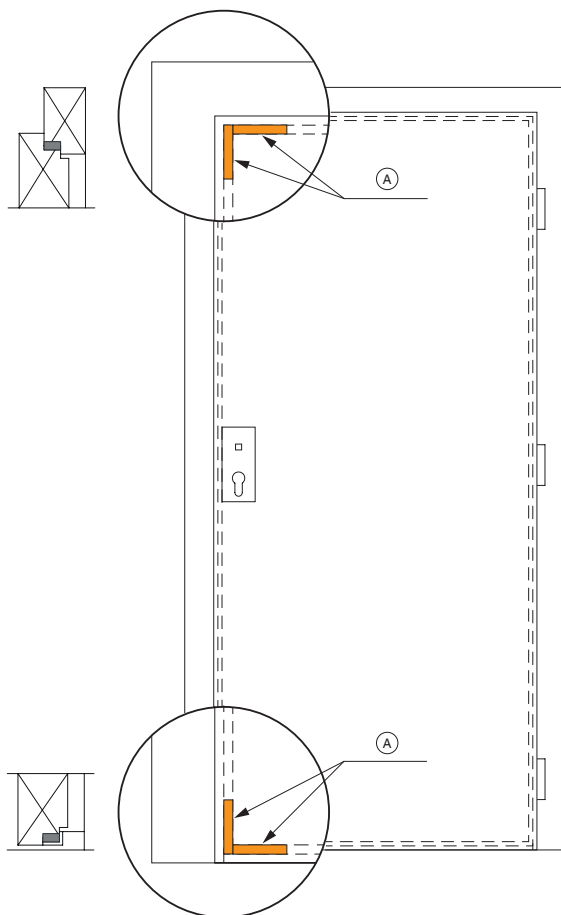

Reactive forces can occur during transport and loading and unloading processes, especially when supported by aids such as suction cups, transport nets, forklift trucks or cranes, which can lead to damage or incorrect loading of the installed fitting. The following instructions must therefore be observed and taken into account for all transport, loading and unloading processes:

- › The type and application points of force during transport and during loading and unloading processes have a considerable effect on the reactive forces that occur.
 - The force application points must always be selected so that the resulting reactive forces are absorbed in accordance with the design of the fitting for the intended installation position. This applies in particular to the bearing points.
- › When transporting door and window elements, considerable reactive forces occur due to vibrations, which can also cause damage or incorrect loads on the installed fitting.
 - Always use transport securing devices (e.g. spacer blocks) adapted to the respective rebate clearance to hold the sash in the intended position in the frame during transport and thus transfer the reactive forces that occur directly from the sash via the frame.
 - If possible, door and window elements should always be transported in the intended installation position so that the resulting reactive forces are absorbed in accordance with the design of the fitting for the intended installation position. This applies in particular to the bearing points. If transport in the intended installation position is not possible, the respective sashes must be unhinged and transported separately from the associated frame.

In addition, it is recommended that the following guidelines be observed:

- › TLE.01 from VFF (German Window and Facade Association (Verband Fenster + Fassade)) The correct handling of ready-to-install windows and external doors during transport, storage and installation

(Source: www.guetegemeinschaft-schloss-beschlag.de/Pruefen-Zertifizieren/Richtlinien/VHBH)

4. Technical data

Optional electronic components (e.g. A-TS Comfort motor, power supply, UPS), as well as access solutions and interfaces are described in the installation instructions "A-TS Comfort motor, access solutions and interfaces" - order number [760322](#).

5. Certificates and proof of performance

5.1 Information according to EN 179 or EN 1125

1309 EN 179:2008 Emergency exit lock Type 3 - 7 - 5/6 - B - 1 - 4 - 5 - 1/2 - B/D Mayer & Co Beschläge GmbH Alpenstraße 173 5020 Salzburg Austria 26 1309-CPR-0543

1309 EN 1125:2008 Panic door lock Type 3 - 7 - 6 - B - 1 - 4 - 2 - 1/2 - A/B - B Mayer & Co Beschläge GmbH Alpenstraße 173 5020 Salzburg Austria 26 1309-CPR-0544

5.2 Classification key according to EN 179:2008

Item 1 Item 2 Item 3 Item 4 Item 5 Item 6 Item 7 Item 8 Item 9 Item 10

3	7	5/6	B	1	4	5	1/2	A	B/D
---	---	-----	---	---	---	---	-----	---	-----

Item	Product property	Class/type	Description of the class
1	Class of use	3	high frequency of use
2	Continuous functionality	6	100,000 test cycles
		7	200,000 test cycles
3	Mass of the door	5	up to 100 kg
		6	up to 200 kg
		7	over 200 kg
4	Suitability for use on fire/ smoke protection doors	0	Not approved for use on fire/smoke protection doors
		A	suitable for use on smoke protection doors
		B	Suitable for use on smoke and fire protection doors on the basis of a test in accordance with EN 1634-1
5	Safety - personal protection	1	highest level
6	Corrosion resistance	3	96 h = high corrosion resistance
		4	240 h = very high corrosion resistance
7	Security - burglary protection	2	1 000 N
		3	2 000 N
		4	3 000 N
		5	5 000 N
8	Protrusion of the operating element	1	Protrusion up to 150 mm (high protrusion)
		2	Protrusion up to 100 mm (normal protrusion)
9	Operation type	A	Push handle operation
		B	Push plate operation
10	Application area of the door	A	Outward-opening single-sash escape door, double-sash escape door: active or passive sash
		B	outward-opening single-sash escape door only
		C	outward-opening double-sash escape door: passive sash only
		D	inward-opening single-sash escape door only

5.3 Classification key according to EN 1125:2008

Item 1	Item 2	Item 3	Item 4	Item 5	Item 6	Item 7	Item 8	Item 9	Item 10
3	7	6	B	1	4	2	1/2	A/B	B

Item	Product property	Class/type	Description of the class
1	Class of use	3	high frequency of use
2	Continuous functionality	6	100,000 test cycles
		7	200,000 test cycles
3	Mass of the door	5	up to 100 kg
		6	up to 200 kg
		7	over 200 kg
4	Suitability for use on fire/ smoke protection doors	0	Not approved for use on fire/smoke protection doors
		A	suitable for use on smoke protection doors
		B	Suitable for use on smoke and fire protection doors on the basis of a test in accordance with EN 1634-1
5	Safety - personal protection	1	highest level
6	Corrosion resistance	3	96 h = high corrosion resistance
		4	240 h = very high corrosion resistance
7	Security - burglary protection	2	Panic locks are primarily intended for operating a door from the inside; the requirements for burglary protection are secondary to those for the protection of persons
8	Protrusion of the horizontal operating rod	1	Protrusion up to 150 mm (high protrusion)
		2	Protrusion up to 100 mm (normal protrusion)
9	Operating type of the horizontal operating rod	A	Panic door lock with handle bar operation
		B	Panic door lock with pressure rod operation
10	Application area of the door	A	single-sash door, double-sash door: active or passive sash
		B	only single-sash door
		C	double-sash door: passive sash only

5.4 Certificate

A list of all elements that have been tested and approved for use with this emergency exit/panic door lock and that may be packaged separately can be found in the certificate at www.maco.eu.

5.5 Declarations of performance

EN 179



www.maco.eu/assets/760362

EN 1125



www.maco.eu/assets/760360

6. Intended use



WARNING

The safety features of this product are an essential prerequisite for its compliance with EN 179 and EN 1125.

No changes may be made that are not described in these instructions!



CAUTION

These instructions only apply to labelled versions of the A-TS automatic lock that are explicitly approved for use in emergency exit and panic doors.

- › The tested and listed combinations of operating element (panic lock in accordance with EN 1125: pushbar handle bar (type A) or touchbar pressure rod (type B); emergency exit lock in accordance with EN 179: lever handle (type A)) and door lock (A-TS) are only tested and approved for use in vertical, rectangular, single-leaf swing doors made of timber, PVC, aluminium, steel or combinations thereof as emergency exit or panic doors in permanent residential or commercial buildings.
- › CE conformity in accordance with EN 179 or EN 1125 only applies if the locking counterparts (individual striker plates and single piece door strikers) approved, tested and certified by MACO are used in accordance with the catalogue or installation instructions.
- › The installation of these locks is only permitted in single-sash emergency exit and panic doors with "E changeover function"!
- › Use in fire and smoke protection doors is also permitted if all normative requirements are met.
- › Maximum application areas and sash weights in accordance with EN 179 and EN 1125:
door sash height: max. 2,520 mm
door sash width: max. 1,320 mm
door mass: max. 200 kg

single-sash door

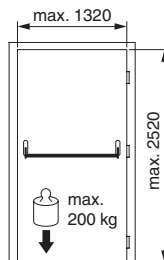

7. Reasonably foreseeable misuse

Misuse exists, among others:

- › for use in double-sash rotating doors
- › for use in swing, revolving or folding doors
- › for use in glass doors
- › if the specified operating range of the operating rod or lock is exceeded or not reached
- › if the specified weight range of the hinges used is exceeded
- › when used in doors that exceed the maximum deformation of the frame and/or the sash of 5 mm during the test (in accordance with EN 179 or EN 1125), as well as if deformations of the door leaf or changes in the seal closure occur due to improper installation of the door leaf, temperature fluctuations or direct sunlight; such deformations can impair or prevent proper locking or unlocking of the locking system and thus possibly lead to the door not being able to be locked or opened
- › for use in rooms with high levels of dust, corrosive atmospheres, high electrostatic charge or damp rooms
- › for use in hollow chamber doors if they are not explicitly suitable for this purpose



CAUTION

The following instructions regarding the material of the fitting must be observed. Otherwise, the fitting may be damaged. In addition, all warranty claims may be invalidated!

- › The fitting described in these installation instructions is made of galvanised metal, passivated and sealed in accordance with EN ISO 2081:2018. It may not be used in environments with aggressive, corrosive air contents (e.g. in swimming pools, stables, buildings near the coast, polluted industrial areas, buildings for processing in the chemical industry, etc.). The fitting is also not suitable or intended for use in acidic woods (oak, larch, teak, etc.) and woods with aggressive ingredients/surface treatments.
- › If the fitting is to be used in demanding environments and with demanding materials, please contact your MACO contact person before installation.
- › Do not use acid-treated sealants, as these lead to corrosion of the fitting.
- › The door elements may only be surface-treated (painting, varnishing, glazing, oiling, etc.) before the fitting is installed. Subsequent surface treatment can impair the function of the fitting. In this case, all warranty, guarantee, compensation and product liability claims, as well as other liability claims against MACO shall lapse.
- › The surface of the fitting may not be damaged during processing. Otherwise, after a while, this leads to white or red rust, which destroys the components. Damaged parts must be replaced.



Failure to observe the following information may result in damage to the fitting!

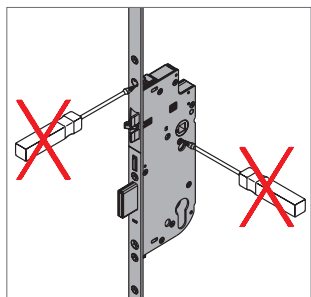

Do not open the lock box under any circumstances!

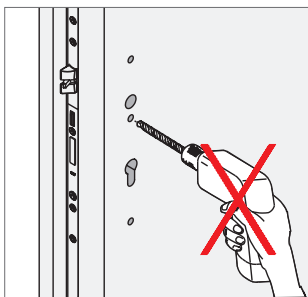

Drill all holes before installing the lock!

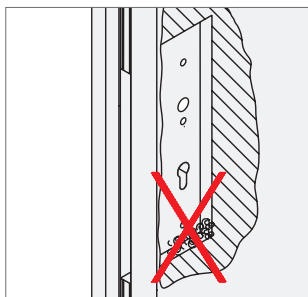

Remove chips from the milling bag!

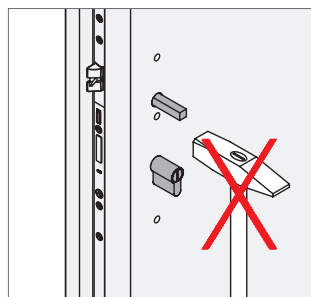

Do not force the lever handle pin through the lock follower!

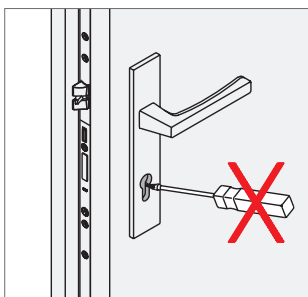

Only lock the lock with the corresponding installation key!

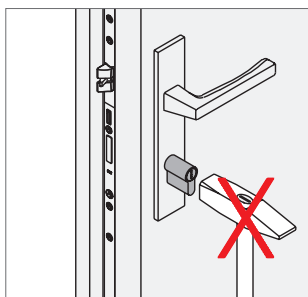

Do not use force when fitting the cylinder!

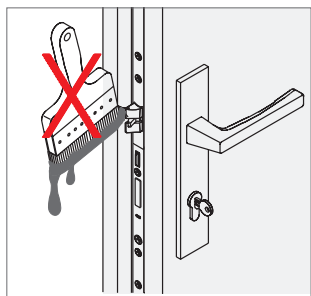

Do not paint or varnish the lock bolt and latch!

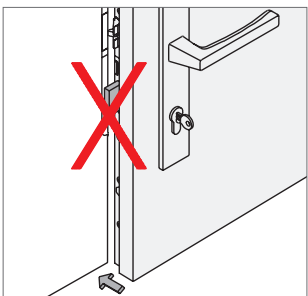

Do not lock the bolt when the door is open!

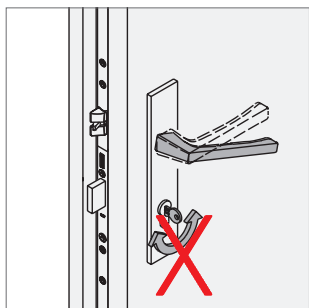

Do not operate the lever handle and key at the same time!

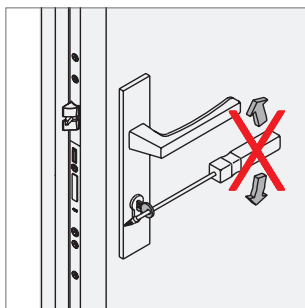

Do not turn the key by force (other levers)!

The bolt of the main lock and, in the case of multi-point locks without door tightening, all bolts of the secondary locks must not rub the strike plate. Use the adjustment options on the striker plates or door hinges for this. It is not permitted to adjust the holes in the striker plates.

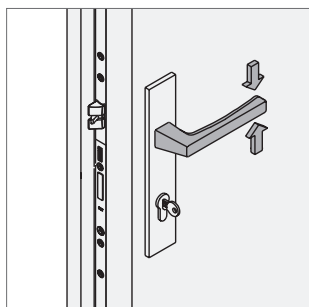

Only apply load to the lever handle in the normal direction of rotation! Apply a maximum force of 15 kg in the operating direction (on the lever handle)!

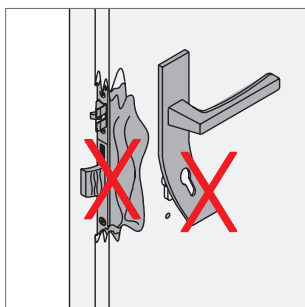

The multi-point lock must be replaced as soon as traces of force are visible!

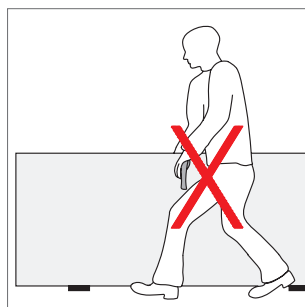

Do not carry the door leaf by the lever handle!

8. Notes for the processing



DANGER

Danger to life and limb due to blocked or delayed escape!

Failure to comply with the processing specifications can lead to restricted or completely obstructed door opening in the event of a hazard. It is imperative that you comply with the following specifications in this section!



CAUTION

Failure to observe the following instructions will also invalidate your liability, warranty, product liability and any separate guarantee claims.

- › The installation of the door lock (A-TS) and the operating element (lever handle, pushbar handle bar (type A) or touchbar pressure rod (type B)) can be found in the instructions for the respective component and must be observed!
- › If a panic bar handle is used, its rotary movement must be matched to the lock follower, but must have an angle of rotation of at least 35°.
- › Damaged components may not be repaired under any circumstances!
- › When installing locks in combination with lever handle operation, possible safety risks (trapping of fingers, entanglement of clothing, etc.) should be avoided as far as possible. This applies in particular to doors with stepped surfaces.
- › Ensure that the components are in perfect condition before installation. Damaged or defective components must not be used under any circumstances! A-TS may only be used in perfect condition!
- › The door may not be warped and the sash and frame must be parallel over the entire height.
- › Cut-outs must be made according to the drawing.
- › All impurities, e.g. chips in the milling area, must be removed.
- › Check the rebate clearance: evenly all round;
 - timber: 4 mm rebate clearance: 4 mm (± 1 mm),
Rebate clearance 12 mm: 12 mm (± 1 mm)
 - PVC: 12 mm (± 1 mm)
 - aluminium: according to the specifications of the profile manufacturer (± 1 mm)
- › All fastening screws must be screwed in correctly and at right angles to the faceplate and the striker plate. The screw diameter must be $\varnothing 4$ mm, the screw length must be adapted to the profile system.
- › Never make changes to the fitting parts!



- › The combination of components is only permitted in the manner shown or described!
- › The A-TS is designed for installation in vertically installed house, flat and side entrance doors made of PVC, timber, aluminium or steel and combinations thereof.
- › Install all fitting parts correctly as described in these instructions and follow all safety instructions!
- › Observe the material instructions described in these instructions (see page 17).
- › The respective complete fitting may only consist of the specified fittings, or the specifically approved system accessories. The fitting combinations may not be modified, extended or restricted. No liability is accepted for the use of combinations not approved by the factory and/or the use of non-original or non-approved accessories!
- › Improper installation, non-conforming or unusual use, the use of system accessories not expressly approved by MACO, modifications or repair work not expressly authorised by MACO and improper servicing can lead to the dangers listed herein and must be avoided! In addition, liability can then no longer be accepted.
- › A visually altered and damaged fitting may not be repaired under any circumstances, but must be completely replaced.
- › Any measures not expressly authorised by MACO, shall result in the loss of all liability, warranty, product liability and any separately agreed guarantee claims.
- › The specified maximum application areas and sash weights for the individual fitting designs must not be exceeded. The component with the lowest permissible load-bearing capacity determines the maximum weight! The specifications for application areas, sash weights and processing guidelines of the profile manufacturer or system provider must be strictly adhered to!
- › Before delivery, the door manufacturer must check the proper functioning of the emergency exit/panic door in accordance with the currently valid regulations. In particular, it must be ensured that the maximum release forces are not exceeded.
- › During initial commissioning, the tests to be carried out must be documented in the maintenance log - order number [760372](#).
- › If in doubt, please consult your MACO contact person!

9. Notes on differentiating between emergency exit and panic doors

› An emergency exit lock (= escape door lock in accordance with EN 179) is used in emergencies where panic situations are unlikely.

It enables safe and effective escape through a door with just a single operation to release the emergency exit lock, although prior knowledge of how to operate the lock may be required. If it is foreseeable that people will push against the door leaf in the event of panic, a panic door lock in accordance with EN 1125 should be used.

› A panic door lock (= escape door lock in accordance with EN 1125) is used in places where panic situations can occur.

It enables safe and effective escape through a door with little effort. Prior knowledge of how to operate the panic door lock is not required, even if the door is under pressure (e.g. if people are pushing against the door in the direction of escape). In panic situations, the behaviour of an individual person is different from the behaviour of a group of people. If two or more people rush to an escape door (possibly in darkness and/or smoke), it is possible that the first person to reach the door will not necessarily operate the panic door lock, but will push against the door surface (door under pressure), while other people will try to operate the horizontal operating bar by hand or body pressure.

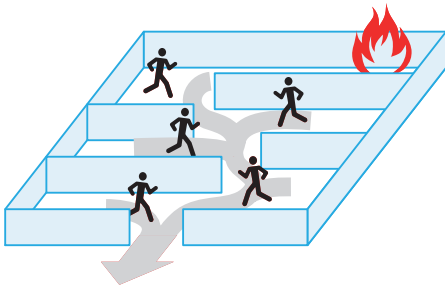

Fig. Emergency exit situation - schematic representation

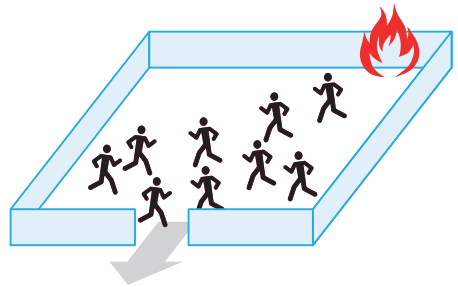
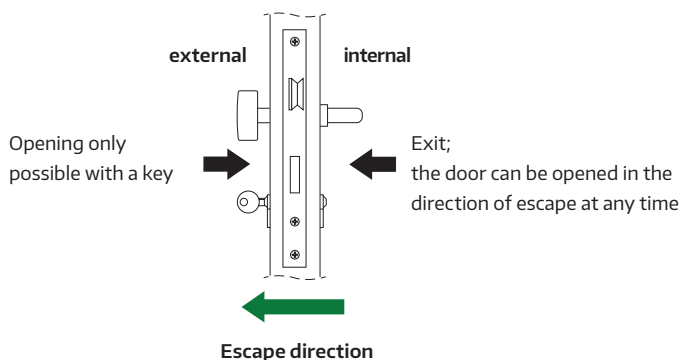

Fig. Panic situation - schematic representation

10. E changeover function

- › The changeover function is for doors where unauthorised opening from the outside must be prevented.
- › The door can only be opened against the direction of escape after unlocking and only with the key.
- › After using the escape function, access against the direction of escape is blocked again after the door closes and it is therefore NOT possible to go back.



Pictogram

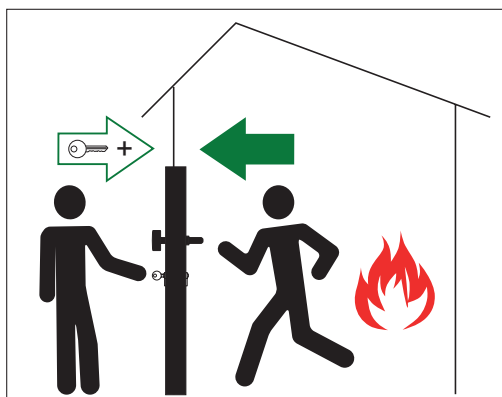

11. Installation and fastening instructions for the fabricator, which are required directly in the EN 179 and EN 1125 standards

(in accordance with EN 179:2008 and EN 1125:2008, Annex A in each case)

The manufacturer of an emergency exit or panic door must observe the following:

- › All components (lock and operating rod) must be fastened in accordance with the individual instructions. Different fastening materials may be required for fastening. Through-bolts, reinforcements and rivets can be used for more reliable fastening.
- › Before installing a panic door lock on a fire/smoke protection door, the certification of the fire protection door on which the panic door lock has been tested should be checked to ensure that the panic door lock is suitable for that particular door.
- › Before fitting the emergency exit or panic door lock, the door must be checked to ensure that it stops properly and is not warped.
- › If panic door locks are manufactured in more than one size, it is important that the correct size is selected.
- › Seals (e.g. sash or frame seals, floor seals, etc.) must not impair the function of the emergency exit or panic door lock in any way.
- › The application range of the lock type used must correspond to the door height and the application range of the operation used (handle bar, pressure rod) must correspond to the door width, i.e. the lateral clearance may not exceed 150 mm. The operation should be mounted in such a way that the rod length is as effective as possible!
- › For panic and emergency exit doors that cannot be opened more than 90° or if the width of the escape route is limited, class 2 panic door or emergency exit locks (normal protrusion = protrusion $X \leq 100$ mm) should be used.

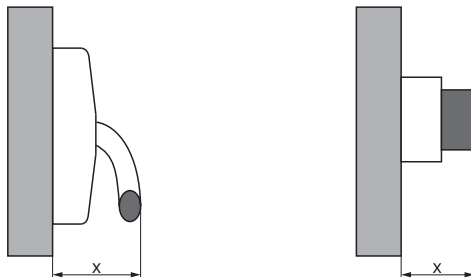

- › The operating element (lever handle, handle bar, pressure rod) should normally be installed at a height of between 900 - 1,100 mm above the surface of the finished floor when the door is closed. If the majority of users of the building are small children, a reduction in the height of the operating element should be considered.

- › The locking elements (latches, hooks and locking bolts) and locking counterparts (individual striker plates and single piece door strikers) should be fitted in such a way that they can be safely engaged. Care should be taken to ensure that the protrusion of the locking elements in the retracted position does not hinder the free movement of the door.
- › No devices other than the locks specified in EN 179 and EN 1125 should be installed to hold the door in the closed position. This does not apply to the installation of door closing devices.
- › If a door closing device is installed to move the door back to the closed position, care should be taken to ensure that this does not hinder the operation of the door by children or elderly and infirm persons.
- › On the inside of the door, directly above the operating element or on the operating element itself, there should be a sign with the words “Press handle to open” or “Press against bar to open” or a pictogram.
- › In both cases, the surface area of the pictogram should be at least 8,000 mm² and the colours should be white on a green background. It should be designed so that the arrow points to the operating element after installation:



- › The operator of such a lock must be familiarised with its intended use.
- › All maintenance work is listed in our operating and maintenance instructions (order number [760267](#)) and must be passed on to the end customer!



DANGER

Danger to life and limb due to blocked or delayed escape!

Failure to comply with the installation and fastening instructions as well as maintenance work can lead to restricted or completely obstructed door opening in the event of danger. It is crucial that you adhere to the above specifications in this section!



CAUTION

If you do not observe the above instructions, your liability, warranty, product liability and any separately granted guarantee claims will also lapse.

12. Additional instructions for fabricators for the use of emergency exit and panic door locks (EN 179 and EN 1125) in fire and smoke protection doors

(in accordance with EN 179:2008 and EN 1125:2008, Annex B in each case)

The manufacturer of an emergency exit or panic door as a fire or smoke protection door must observe the following:

- › The suitability of the fire or smoke protection door for the installation of the emergency exit or panic lock should be checked in advance.

13. Authorised system components and adaptations of locks for use in emergency exit and panic door locks



CE conformity in accordance with EN 179 or EN 1125 only applies if the MACO automatic lock (A-TS) is used with the tested and certified components as per the catalogue or installation instructions.

- › Locking cylinders can only be installed without any restrictions if these locking cylinders are subject to the dimensional standard DIN 18252 and if they are also certified in accordance with EN 1303 or EN 15684.
- › The lock may only be cut to length at the top and bottom ends.

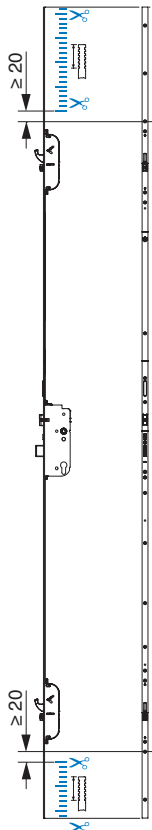

The **maximum permissible cut to length range** at the top extends up to 20 mm above the first screw position above the upper secondary lock.

The **maximum permissible cut to length range** at the bottom extends up to 20 mm below the first screw position below the lower secondary lock.

- › It is permissible to change the latch mounted in the lock to adapt it to the type of opening (left / right).
- › The installation or retrofitting of the tested and certified automatic lock motor in an A-TS lock is permitted.
- › The installation or retrofitting of a tested and certified locking element for the daytime setting function is permitted for emergency exit doors in accordance with EN 179.
- › For panic doors in accordance with EN 1125, only the motorised daytime setting is permitted, without any changes to the lock/striker plate. Removal of the daytime setting screw and use of a day release element and day release opener is not permitted. To return the door to the closed position, it is permissible to use a door closing device to hold the door shut. Care should be taken to ensure that this does not hinder the operation of the door by children, the elderly or infirm.
- › Replacing the standard latch with latch clips with a detached latch with latch clips approved for EN 179 is only permitted in combination with a day release opener.



CAUTION

The use of modular components (e.g. shortening face plate, extension face plate, intermediate face plate) is NOT permitted for emergency exit and panic doors!

14. Latch changeover and replacement of detached latch

Latch with latch clip

Multifunction latch

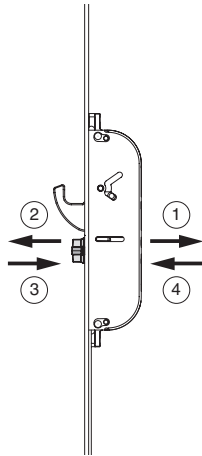
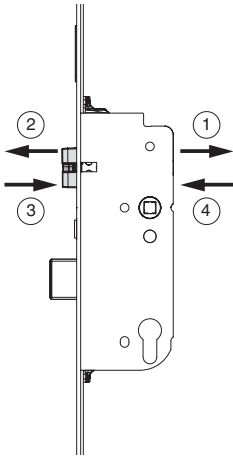

- ① Loosen the screw completely and push it forwards with a screwdriver!
- ② Take out latch!
- ③ Turn the latch over and push the latch all the way in!
- ④ Screw in the screw (torque min. 1.5 Nm to max. 2 Nm)!



Carry out a function check!

15. Installation instructions

15.1 Set up lock for mechanical day release function (fabricator, only EN 179)



DANGER

The mechanical day release feature may not be installed in panic doors in accordance with EN 1125 and fire/smoke protection doors!

Danger to life and limb due to non-guaranteed panic function and non-guaranteed fire/smoke barrier!

If the lock is set up for mechanical day release feature, the main latch is not operated during motorised operation (door does not swing open automatically)!



Only authorised for use in emergency exit doors in accordance with EN 179!

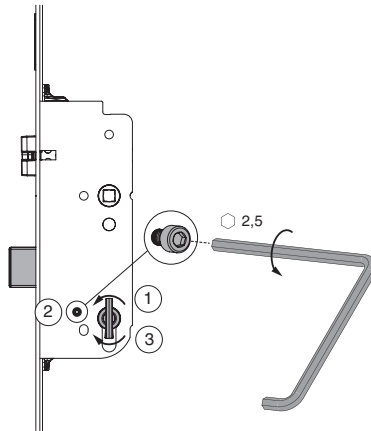

Set up day release function

- ① Locking
- ② Remove the day release screw
- ③ Unlocking

15.2 Installation of day release element on the lock (fabricator, EN 179 only)



DANGER

Danger to life and limb due to non-guaranteed panic function and non-guaranteed fire/smoke barrier!

The day release element on the lock may not be installed in panic doors in accordance with EN 1125 and fire/smoke protection doors!

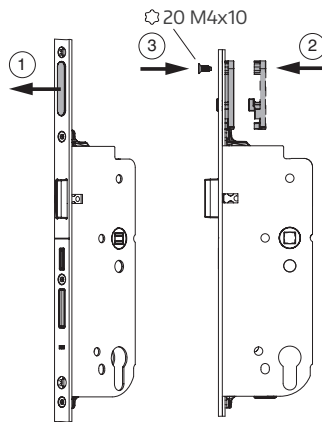

- ① Remove the cover on the face plate.
- ② Position the day release element on the back of the face plate (directly on the bolt above the lock box).
- ③ Screw the day release element to the front of the face plate using the enclosed screw!

15.3 Installation of MACO day release opener with permanent opening on the striker plate (fabricator, EN 179 only)



DANGER

Danger to life and limb due to non-guaranteed panic function and non-guaranteed fire/smoke barrier!

The day release opener on the striker plate may not be installed in panic doors in accordance with EN 1125 and fire/smoke protection doors!



WARNING

When using a day release opener the sash weight may not exceed 100 kg.

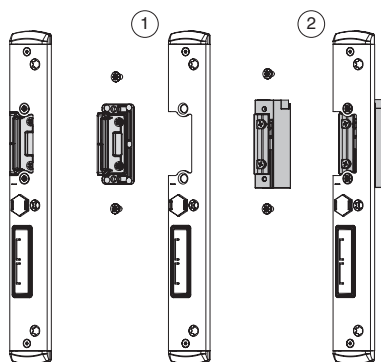

When using a day release opener, a latch with latch clip must be used (see page 29 "Latch conversion and replacement of detached latch").



When using a day release opener in narrow design a detached latch with latch clips is to be used.

- ① Dismantle latch insert.
- ② Install MACO day release opener with permanent opening.

15.4 Day release feature operating instructions (end customer, EN 179 only)

 **DANGER**

Danger to life and limb due to non-guaranteed panic function and non-guaranteed fire/smoke barrier!

The day release feature may not be installed in panic doors according to EN 1125, and in fire/smoke protection doors!

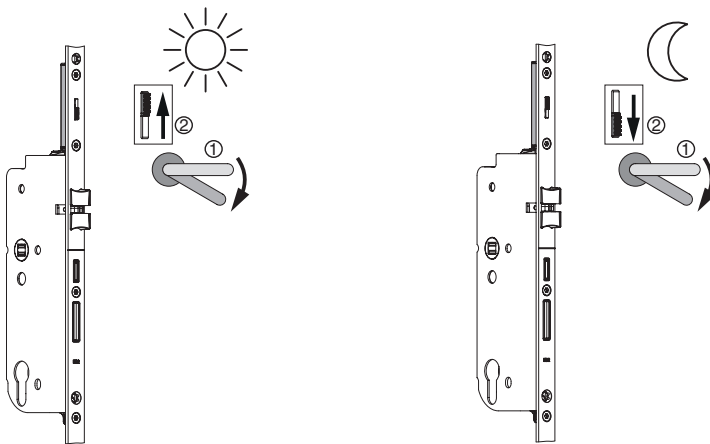

Activate day release feature

- ① Operate the lever handle so that the locking elements and multifunctional latches are retracted!
- ② Push the day release slider upwards and release the lever handle.

Deactivate day release feature

- ① Operate the lever handle so that the locking elements and multifunctional latches are retracted!
- ② Push the day release slider downwards!

The basic A-TS function, automatic locking, is restored!

16. General positioning of striker plates and single piece door strikers

2 multifunctional latches with hooks, 1-sash

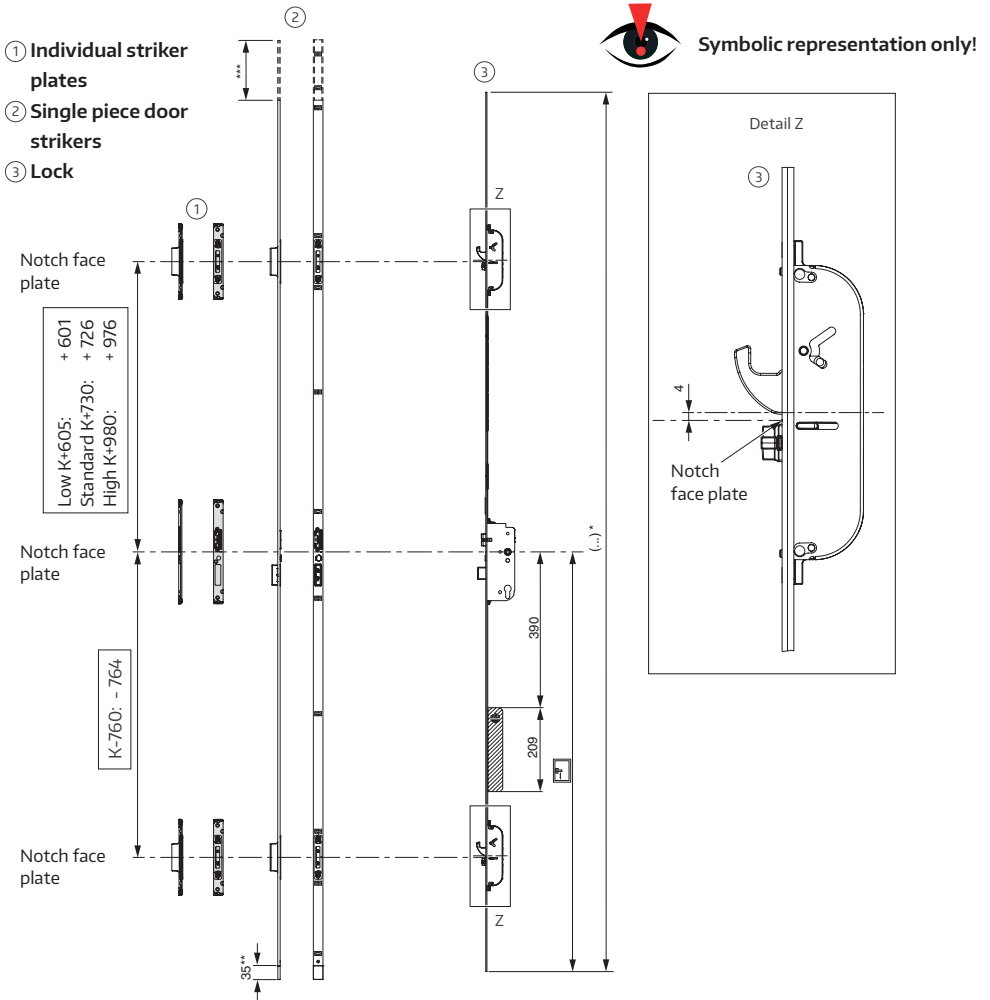

Motor for motorised opening
 * Use cover face plate for higher FFH!
 ** Attachment end for adaptation to threshold (only with timber profile 12 mm rebate clearance, 13 mm offset)
 *** For higher FFH item 102852 use single piece door striker extension (only for timber profile 12 mm rebate clearance, 13 mm offset)

17. Timber profile door constructions

17.1 4 mm rebate clearance

13 mm offset

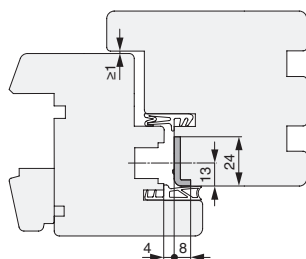

A rebate clearance of 3 - 5 mm must be maintained when installed!

17.2 12 mm rebate clearance

13 mm offset

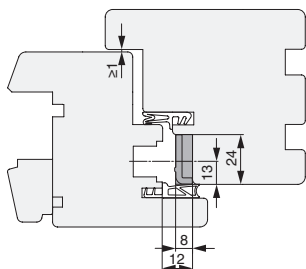

A rebate clearance of 11 - 13 mm must be maintained when installed!

18. Timber profile drilling and milling images

18.1 Lock box and multifunctional latch with hook locking

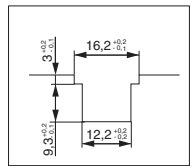
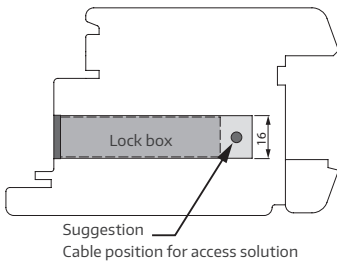
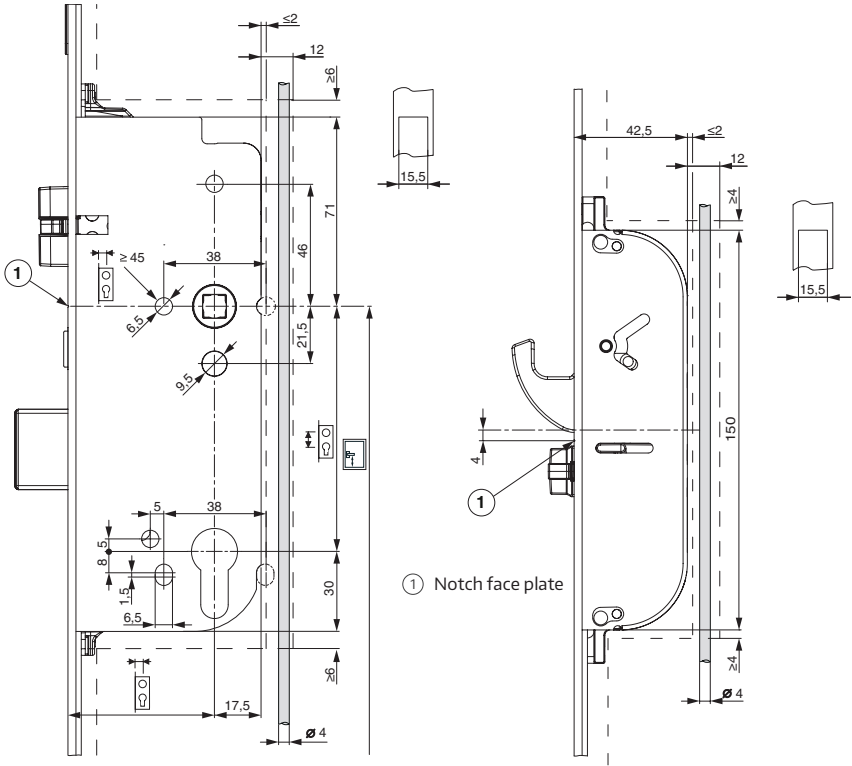

18.2 Latch and bolt striker plate 13 mm offset

4 mm clearance

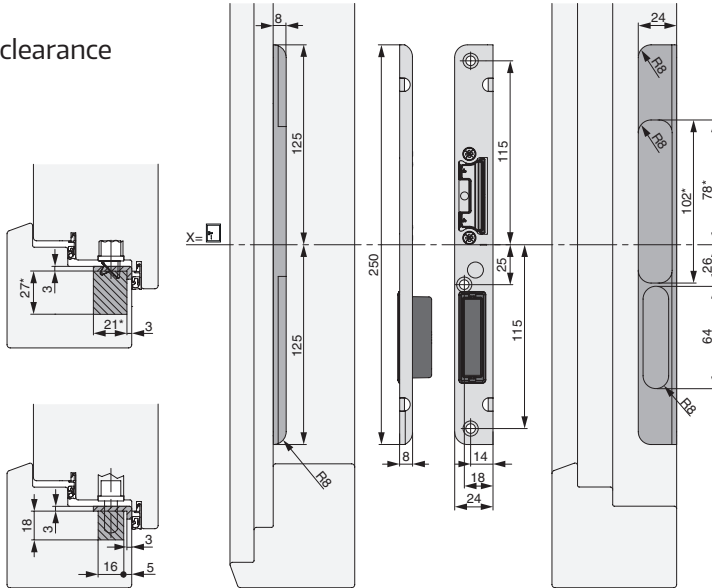

12 mm clearance

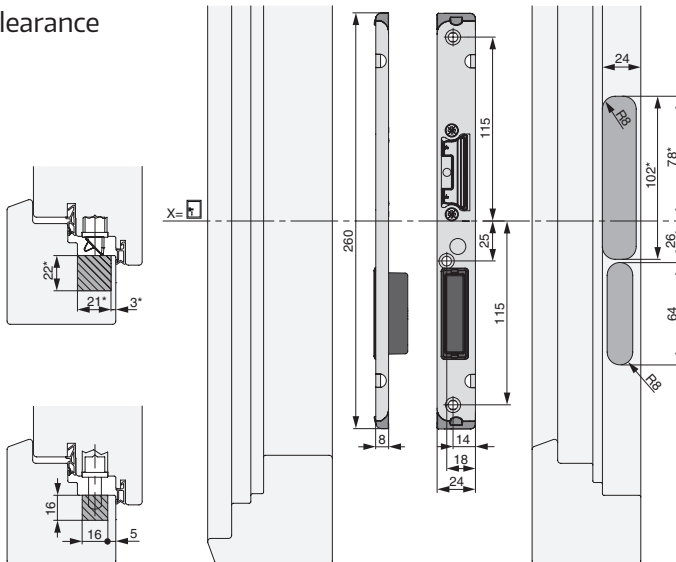

* E-opener milling image

18.3 Multifunctional hook striker plate 13 mm offset

4 mm rebate clearance

12 mm rebate clearance

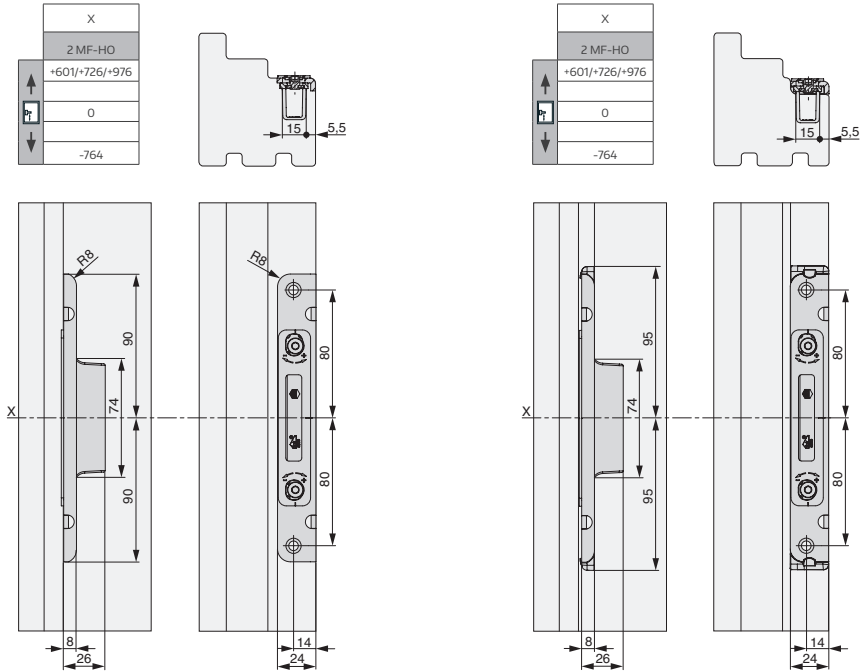

19. Positioning of timber profile striker plates

19.1 4 mm rebate clearance, 13 mm offset

Position of latch and bolt striker plates

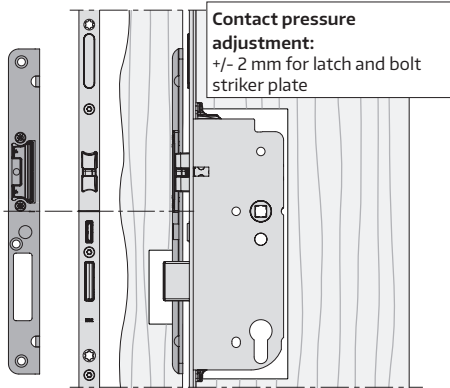

Position of multifunctional hook striker plate

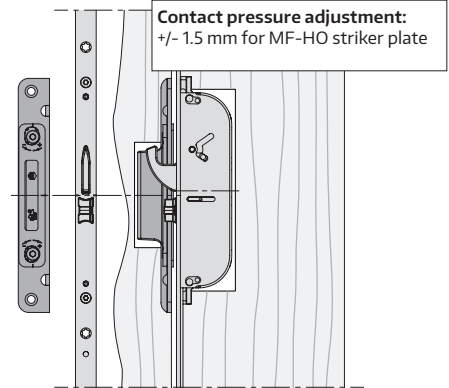

Positioning notch on face plate = notch on striker plates



A rebate clearance of 3 - 5 mm must be maintained when installed!

19.2 12 mm rebate clearance, 13 mm offset

Position of latch and bolt striker plates

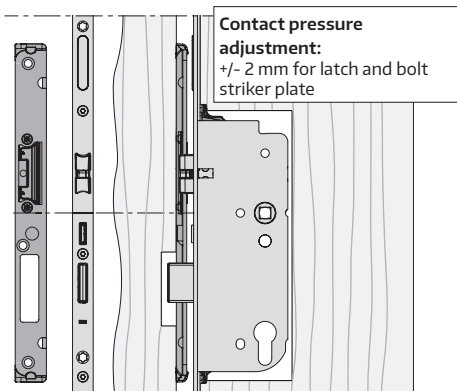

Position of multifunctional hook striker plate

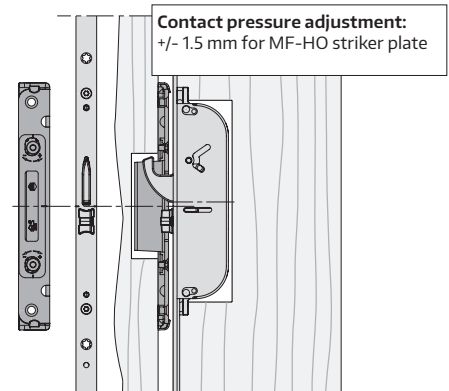

Positioning notch on face plate = notch on striker plates



A rebate clearance of 11 - 13 mm must be maintained when installed!

20. PVC profile drilling and milling images

20.1 Lock box and multifunctional latch with hook locking

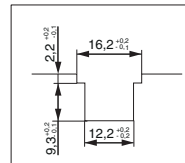
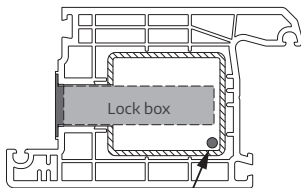
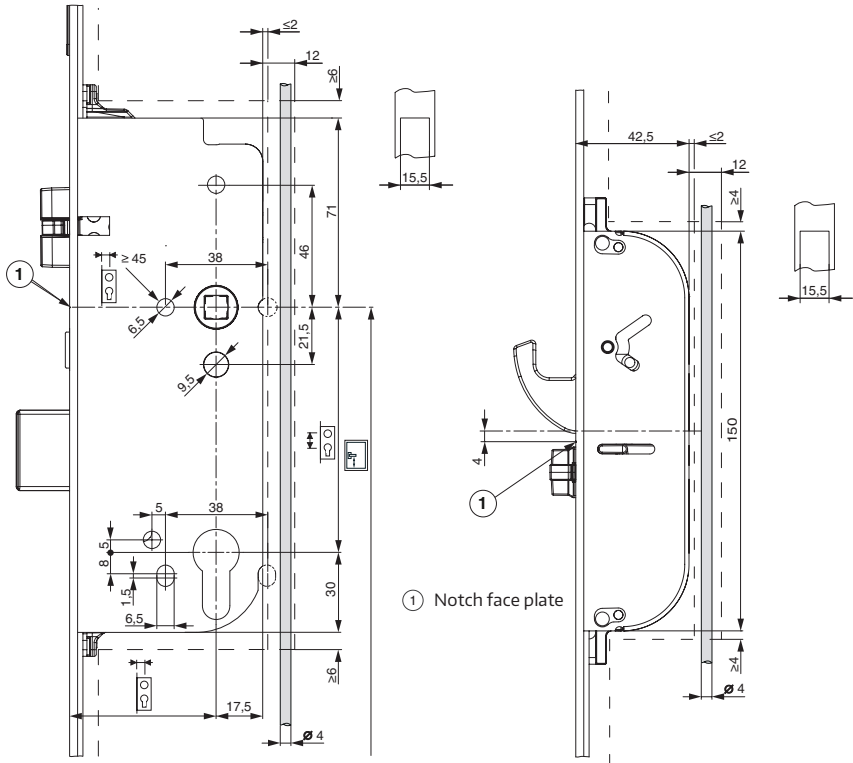

20.2 Latch and bolt striker plate

20.3 Multifunctional hook striker plate

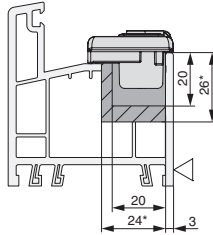

	X
	2 MF-HO
	+601/+726/+976
↑	Pr
	O
↓	-764

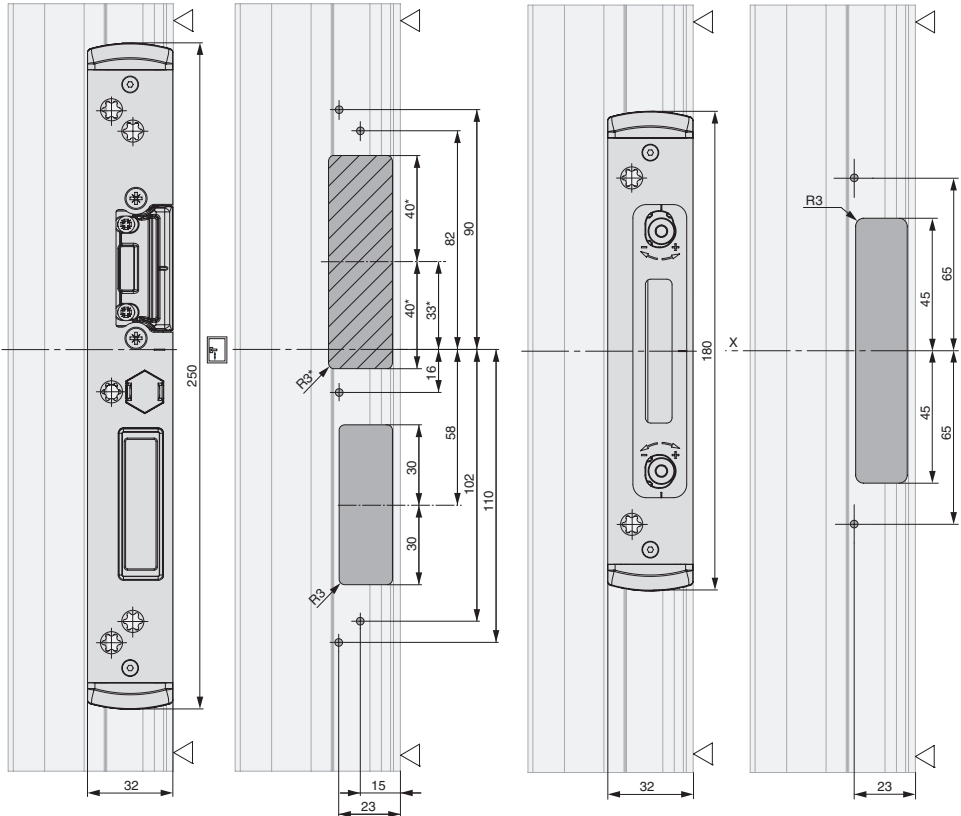
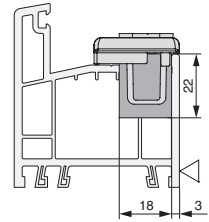

*E-opener milling image

21. Positioning PVC profile striker plates

Positions

Latch and bolt striker plate

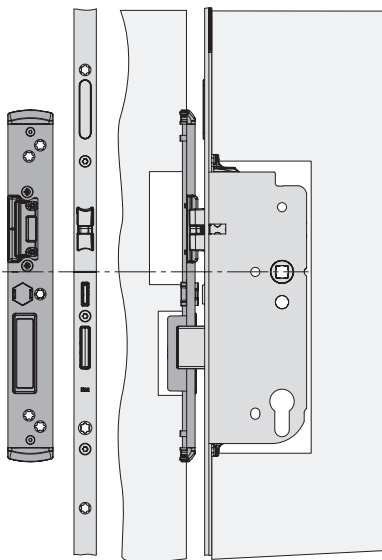

Striker plate, multifunctional latch with hook

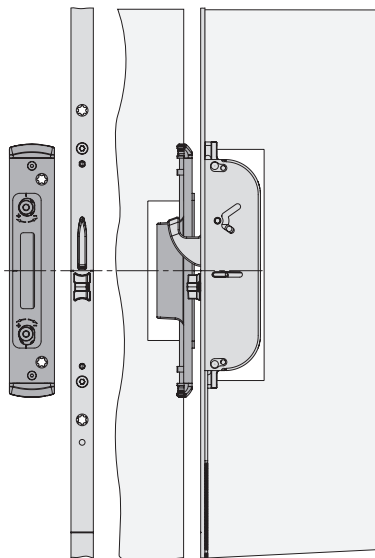

Contact pressure adjustment:

+/- 2 mm for latch and bolt striker plate

+/- 1.5 mm for MF-HO striker plate

Positioning notch on face plate = notch on striker plates



A rebate clearance of 11 - 13 mm must be maintained when installed!

22. Aluminium profile drilling and milling images

22.1 Lock box and multifunctional latch with hook locking

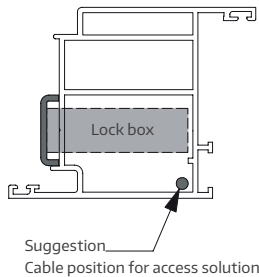
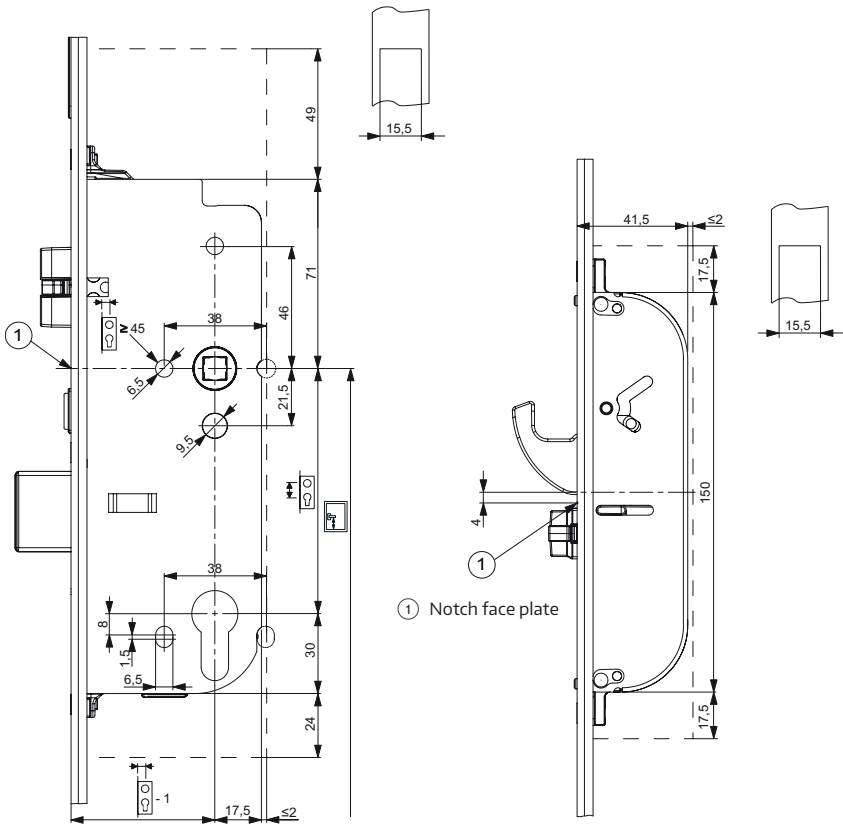

22.4 Latch and bolt striker plate 6 mm

	X
	2 MF-HO
	+601/+726/+976
↑	O
↓	-764

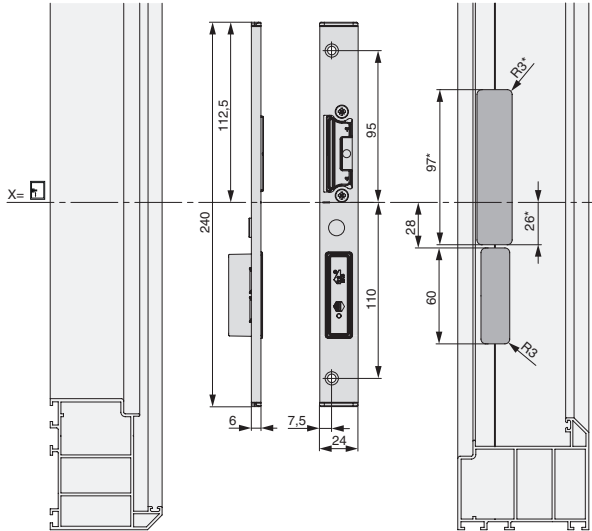
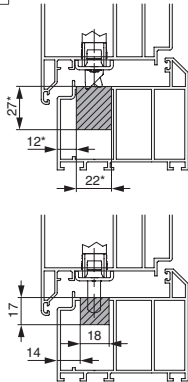

*E-opener milling image

22.5 Multifunctional hook striker plate 6 mm

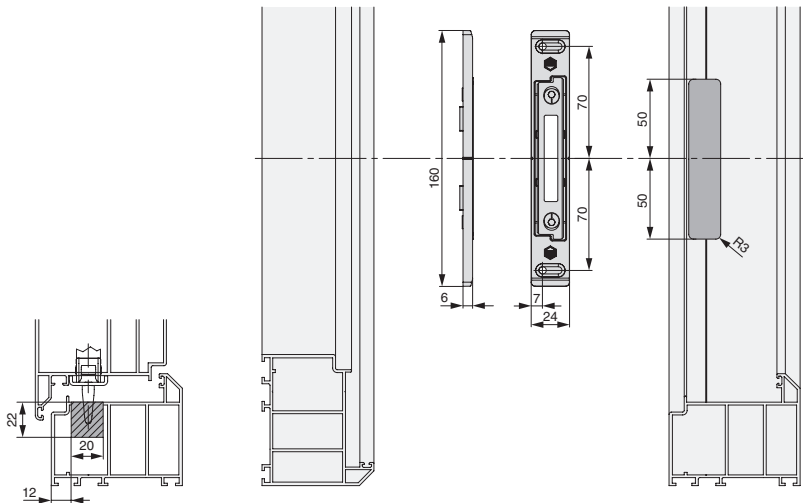

23. Positioning aluminium profile striker plates

Positions

Latch and bolt striker plate

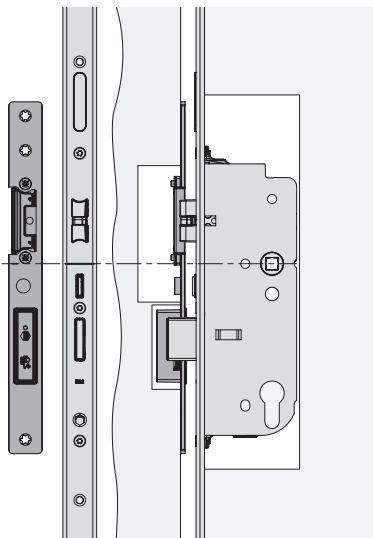

Striker plate, multifunctional latch with hook

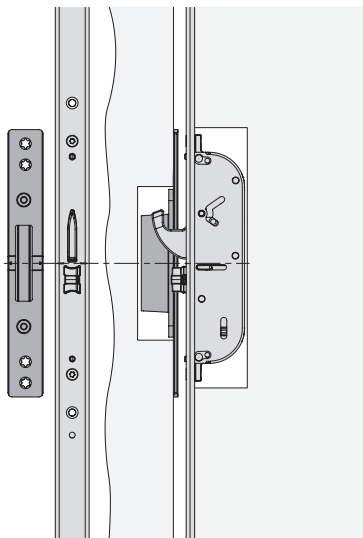

Contact pressure adjustment:

+/- 2 mm for latch and bolt striker plate

+/- 1.5 mm for MF-HO striker plate

Positioning notch on face plate = notch on striker plates



A rebate clearance of 3 - 5 mm must be maintained when installed!

24. Composite drilling and milling images

24.1 Lock box and multifunctional latch with hook locking

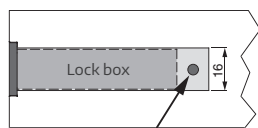
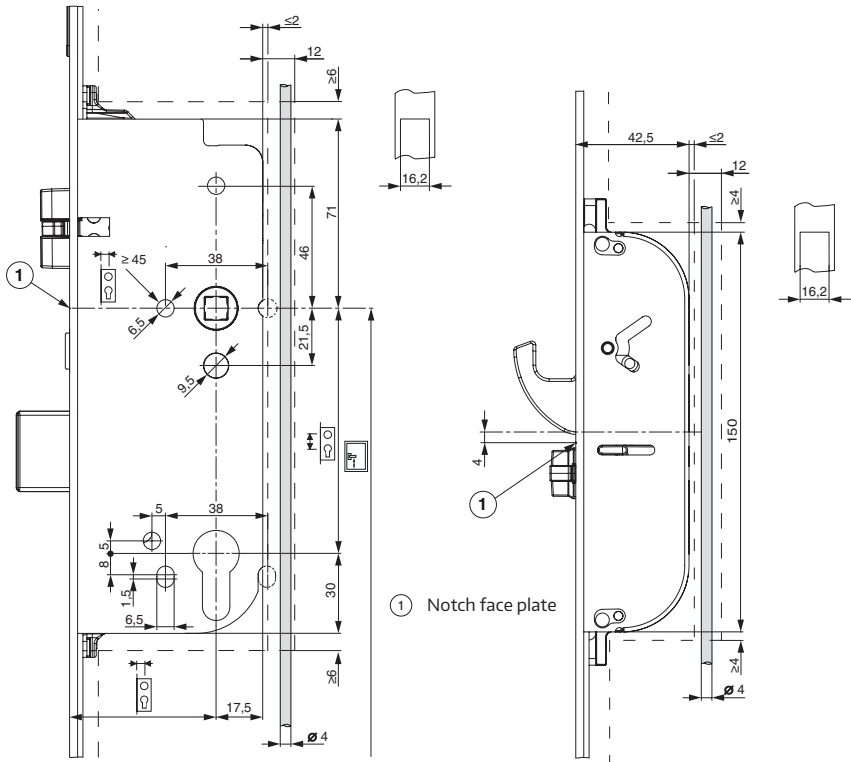

Suggestion
Cable position for access solution

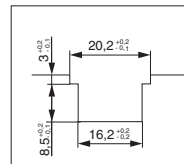

24.2 Latch and bolt striker plate for sash thickness 48 mm

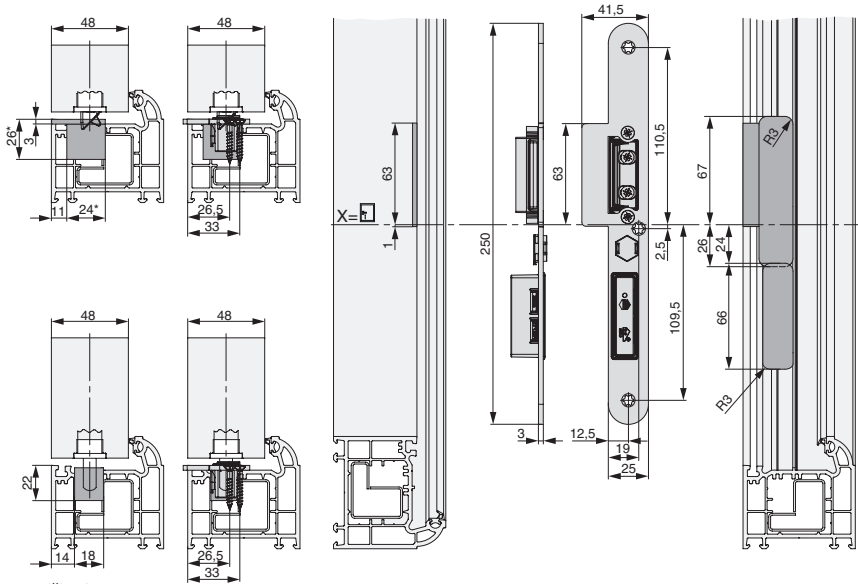

* E-opener milling image

24.3 Multifunctional hook striker plate for sash thickness 48 mm

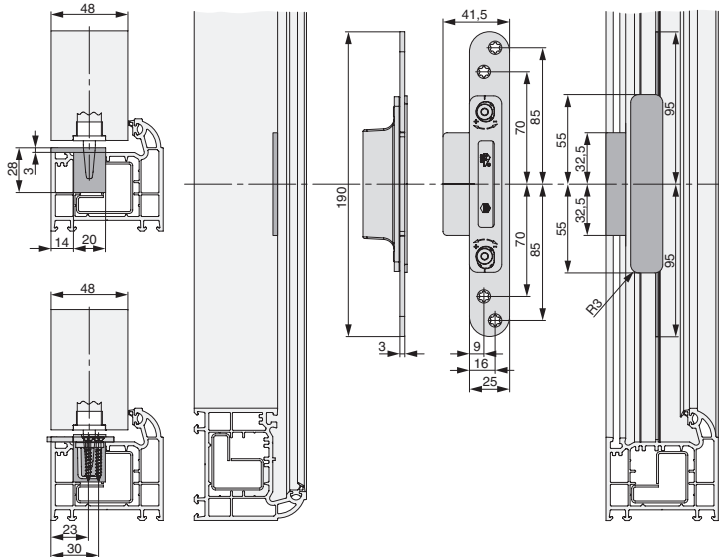

24.4 Latch and bolt striker plate for sash thickness 44 mm

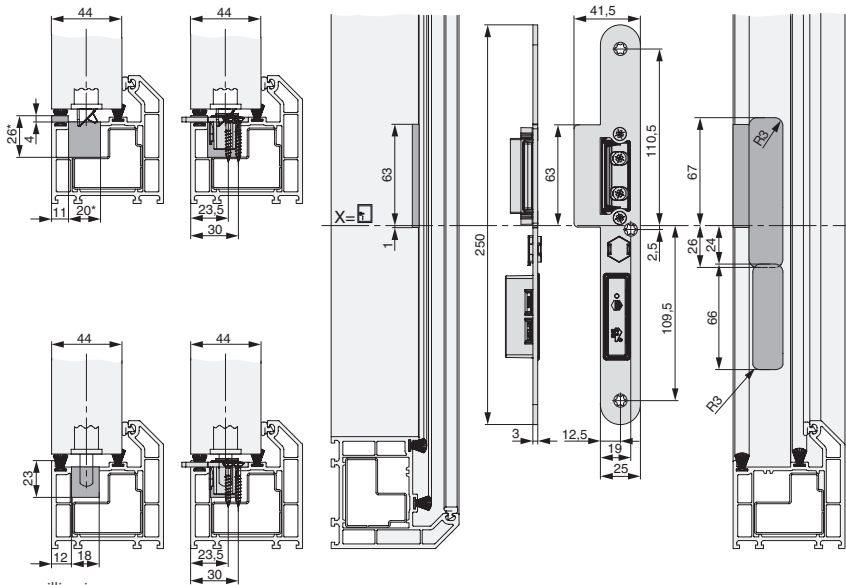

* E-opener milling image

24.5 Multifunctional hook striker plate for sash thickness 44 mm

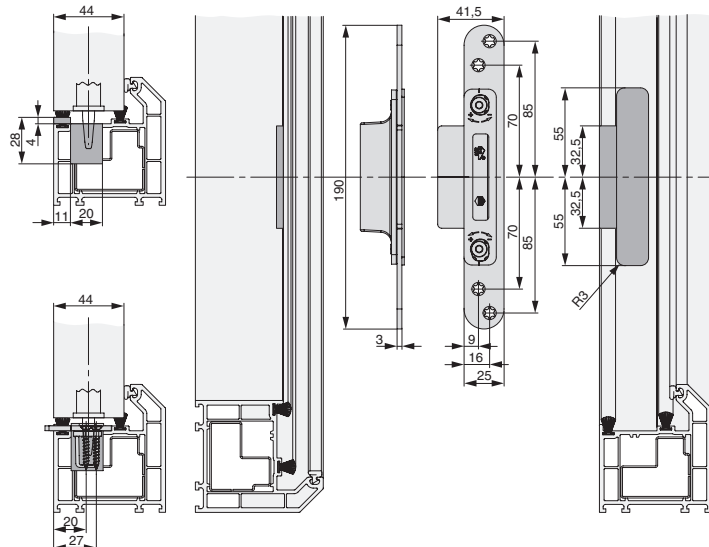

25. Positioning composite striker plates

Positions

Latch and bolt striker plate

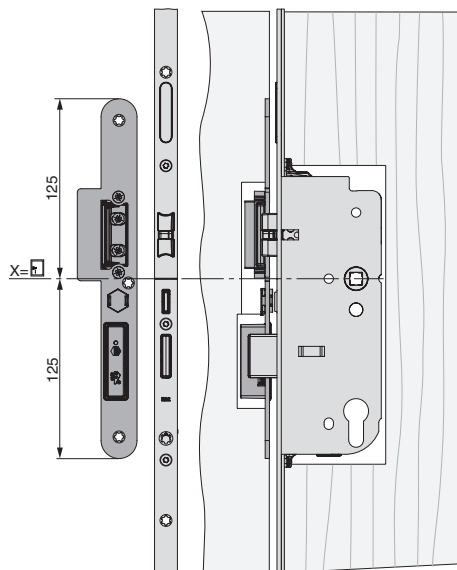

Striker plate, multifunctional latch with hook

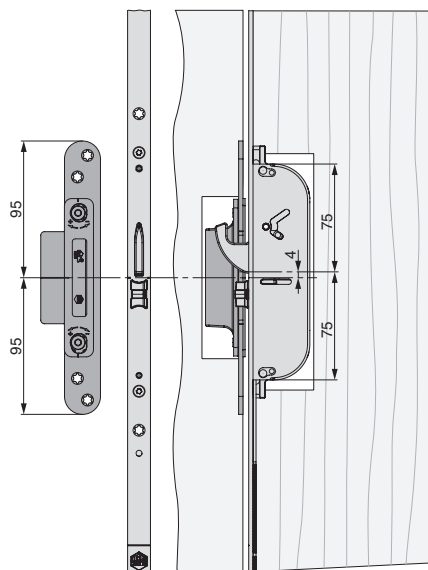

Contact pressure adjustment:

+/- 2 mm for latch and bolt striker plate

+/- 1.5 mm for MF-HO striker plate

Positioning notch on face plate = notch on striker plates



A rebate clearance of 3 - 5 mm must be maintained when installed!



26. Disposal of the fitting

The fitting must be disposed of in accordance with local regulations and laws.

Disposal of the fitting may **NOT BE IN DOMESTIC WASTE!**

Would you like everything from a single source?

With us you get complete solutions for your large surfaces, windows and doors – for timber, PVC and aluminium. Experience our versatile systems range with comprehensive service included. Discover more on our website www.maco.eu, or contact your MACO customer advisor.

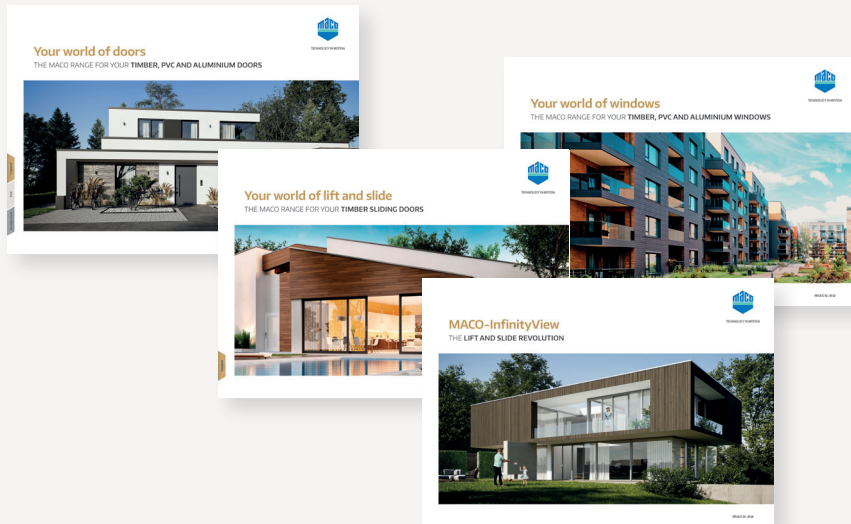

MACO near you:
www.maco.eu/contact



TECHNOLOGY IN MOTION



This document is revised on an ongoing basis.
You can find the current version at <https://www.maco.eu/assets/760368>,
or by scanning the QR code.

Created: 04/2026
Order no. 760368
All rights and modifications reserved.