

Bevestigingsschroef Greep:

DD 56 = HS-Bout M6x70mm
DD 68 = HS-Bout M6x80mm

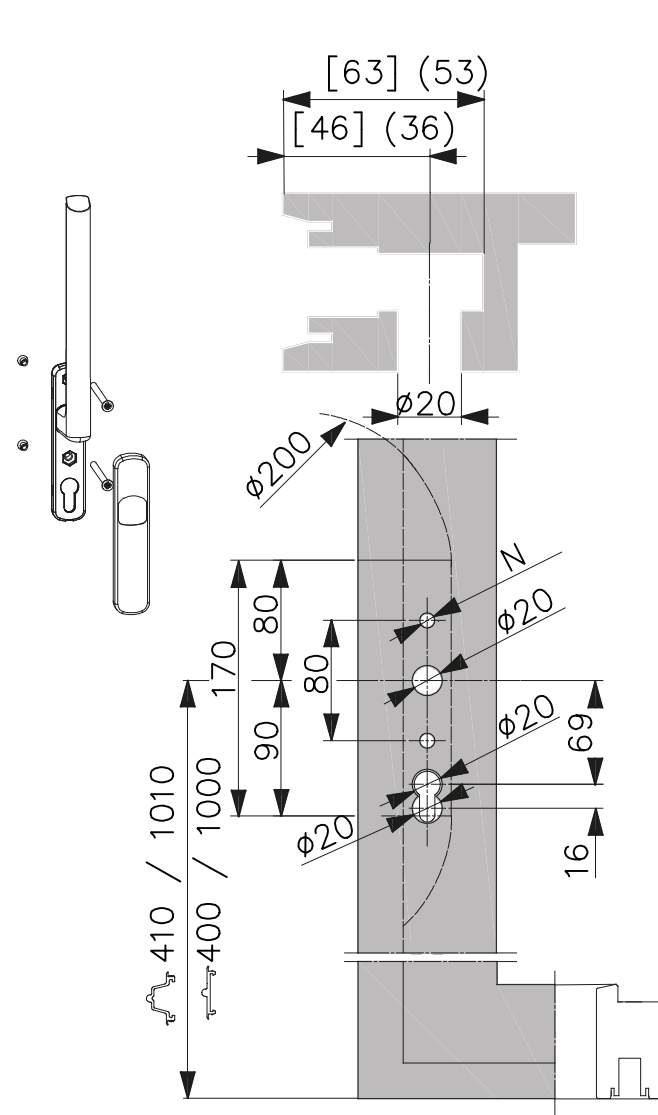

Bevestigingsschroef Greep:

DD 56 = HS-Bout M5x45mm
DD 68 = HS-Bout M5x50mm

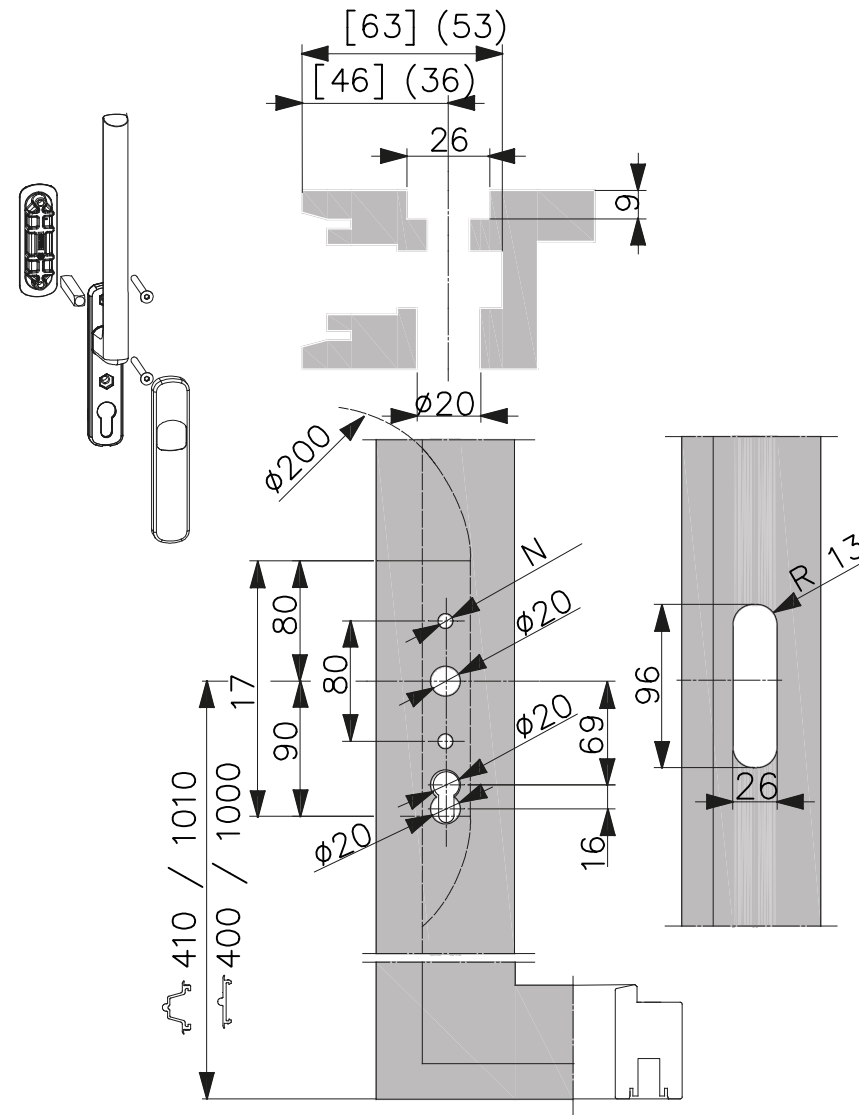

Bevestigingsschroef Greep:

DD 56 = HS-Bout M6x70mm
DD 68 = HS-Bout M6x80mm

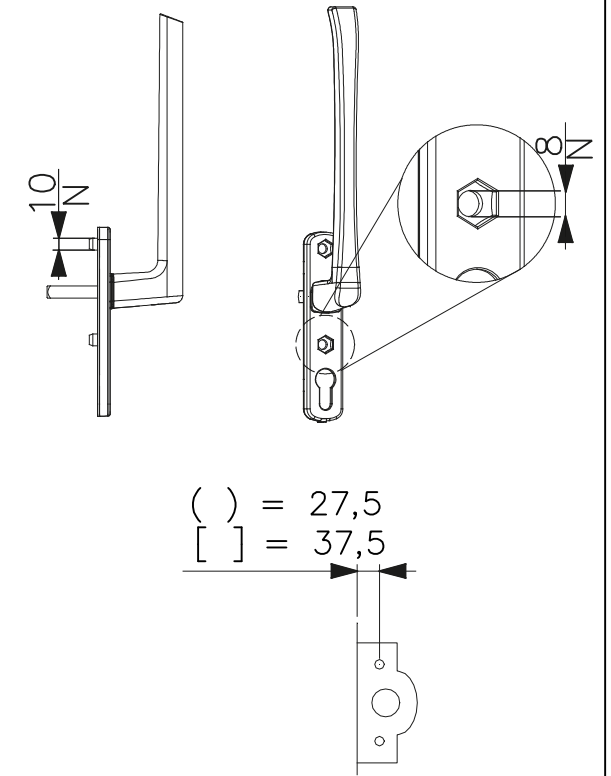

() = 27,5
[] = 37,5

MACO RAIL SYSTEM - Krukgatboring Krukgathoogteboormal - Nr. 203924		Hefschuif Krukgatboring	
 <p>MACO BESCHLÄGE BV POSTBUS 41 7020 AA Zelhem Tel: 0314-659700 www.maco-nl.nl</p>		Datum	Naam
	Get.	01-02-2017	MC
	Gew.	27-05-2020	KV
<p>DEZE TEKENING IS MET DE GROOTSTE ZORG SAMENGESTELD. MACO BESCHLÄGE B.V. AANVAARDT NOCHTANS GEEN VERANTWOORDELIJK- HEID VOOR ENIGE SCHADE VOORTKOMEND UIT ONJUISTHEDEN OF ANDERZINS ONVOLKOMENHEDEN IN DE INHOUD VAN DEZE TEKENING</p>			<p>Tek.No. HS-KRUKGAT</p>